

AMPEX MODEL

MIXER-35

MIXER ASSEMBLY



TM 2012A
SEPTEMBER 1960

AMPEX
PROFESSIONAL PRODUCTS
CORPORATION



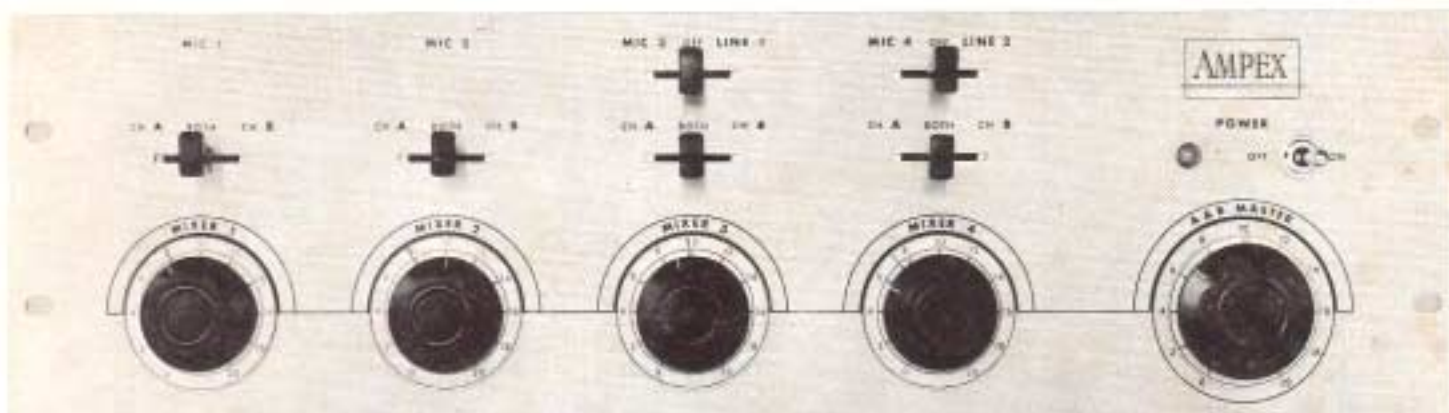
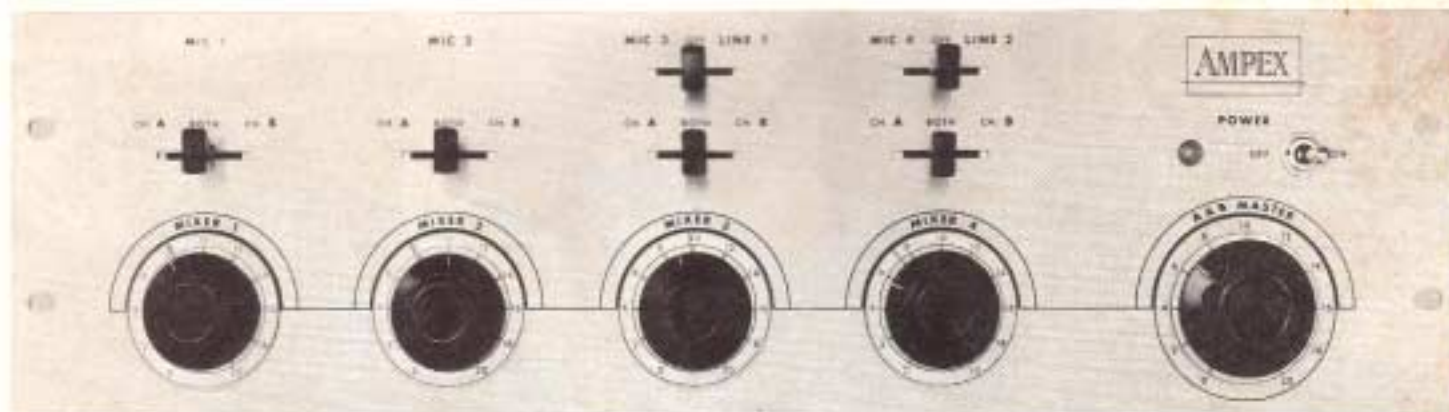

MX-35

MIXER ASSEMBLY

TM 2012A

SEPTEMBER 1960

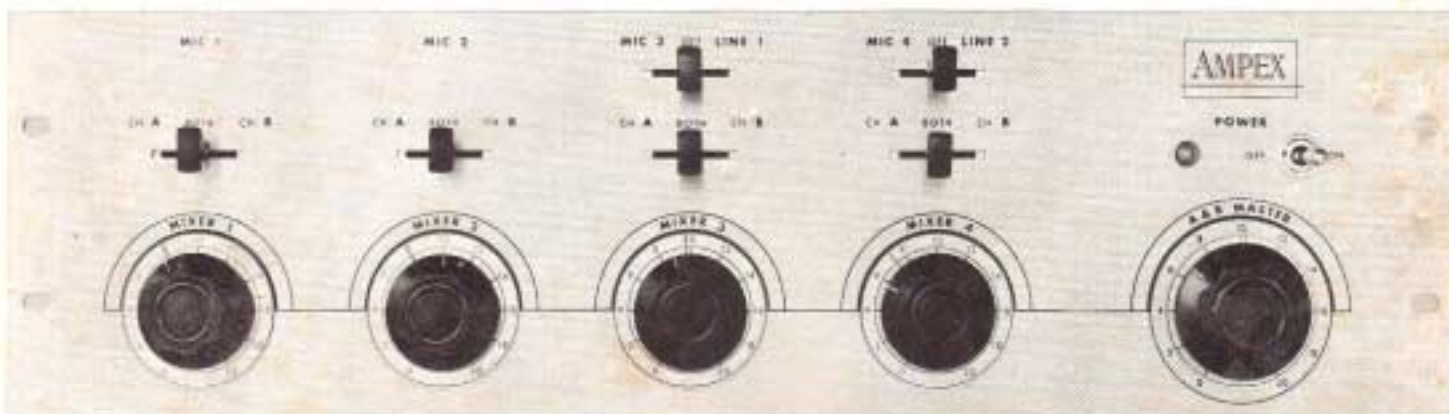
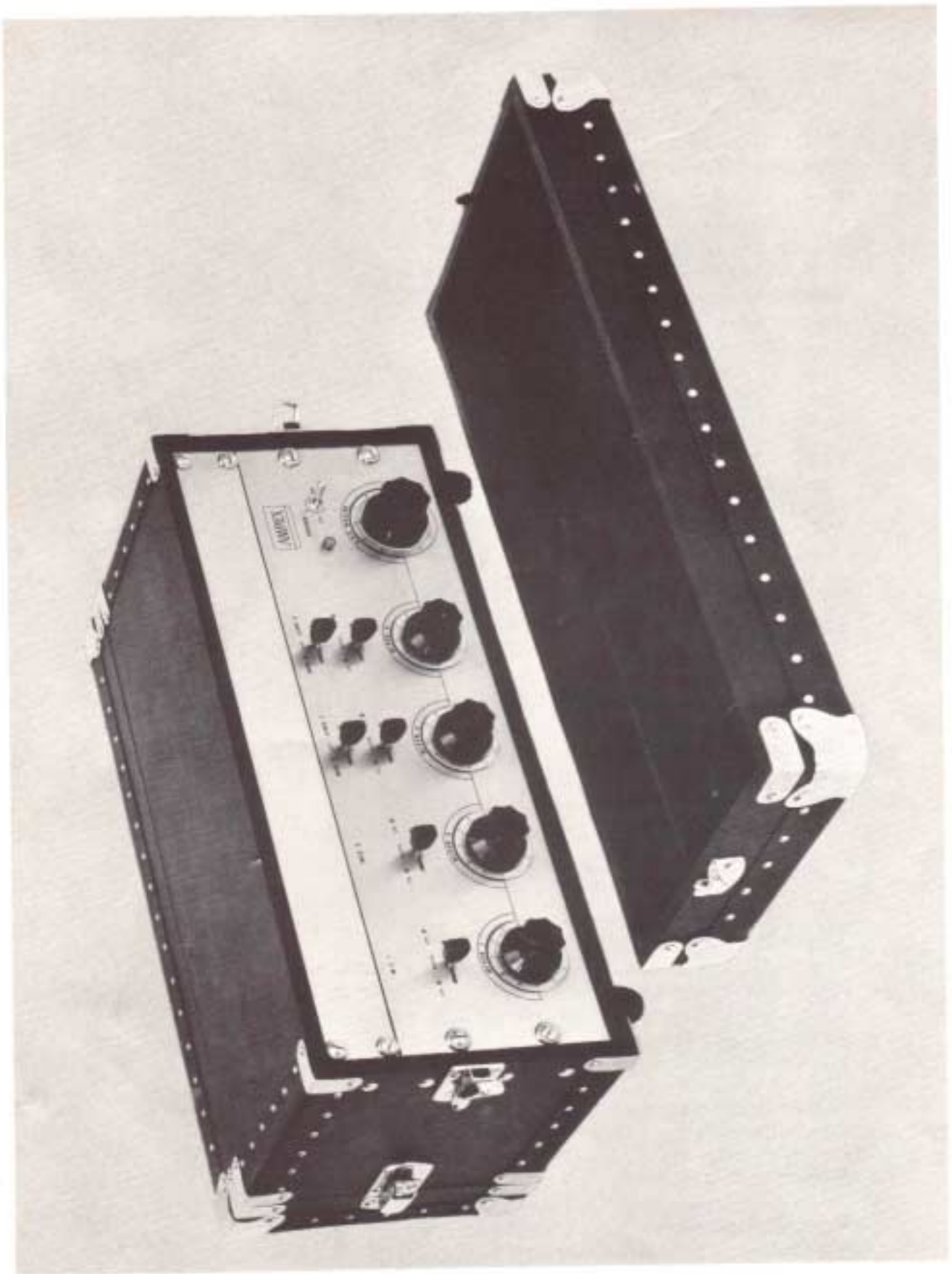

Table of Contents

Section	Topic	Page
1	DESCRIPTION	
	General	1-1
	Performance Characteristics	1-2
2	Equipment Applications	1-3
	INSTALLATION	
	General	2-1
	Installation of Equipment	2-1
3	Installation of Plug-In Items	2-2
	Connections	2-2
	OPERATING INSTRUCTIONS	
	Controls	3-1
4	Applying Power	3-2
	Setting Up the Controls	3-2
	Operation of the Equipment	3-3
	CHECKOUT AND ADJUSTMENT	
5	General	4-1
	Overall Gain Measurement	4-1
	Overall Gain Adjustment	4-2
	Frequency Response Measurement	4-2
6	MAINTENANCE AND TROUBLESHOOTING	
	General Maintenance Information	5-1
	Corrective Maintenance	5-1
	Ordering Parts	5-2
7	Parts List, Mixer Assembly	5-3
	THEORY OF OPERATION	
	Microphone Preamplifiers	6-1
	Output Amplifiers	6-2
	Mixer Coupling	6-2
Power Supply	6-3	

List of Illustrations

1	Ampex MX-35 Mixer Assembly	iv
	Typical Uses of the MX-35 Mixer	1-3
2	MX-35 Mixer Assembly - $\frac{3}{4}$ View	2-2
	Rack Layout (Shown with Ampex 354 Tape Recorder)	2-2
3	Mounting Dimensions	2-2
	Interconnecting Two or More Mixers	2-3
3	Operating Controls	3-2
4	Response and Gain Measurement Set-Up	4-2
5	Troubleshooting the Mixer	5-2
6	Parts Location, MX-35 Mixer	
	Block Diagram, MX-35 Mixer	6-2
	Partial Schematic Diagram, Microphone Preamplifier	6-2
	Partial Schematic Diagram, Output Amplifier	6-2
	Schematic Diagram, MX-35 Mixer	



Ampex MX-35 mixer assembly

DESCRIPTION

GENERAL

The Ampex MX-35 Mixer Assembly provides complete mixing facilities. Six inputs and two outputs are provided. The inputs consist of four microphone inputs and two line inputs. Switching allows any combination of up to four inputs to be connected to either or both outputs. Provisions are also made for coupling up to four mixer assemblies together.

The mixer assembly consists of a single chassis on which is mounted four separate and completely independent microphone preamplifiers and two separate output amplifiers. Switching allows any microphone preamplifier to be connected to either or both of the output amplifiers. Additional switching is provided to bypass two of the microphone preamplifiers (separately) so that two line inputs can be connected to either or both outputs. Individual gain controls are provided as is a master gain control.

On the back panel of the mixer assembly are all connecting and interconnecting provisions for line and microphone inputs, line outputs, power and mixer coupling. A screw-type fuse post is also provided on the chassis back panel.

PERFORMANCE CHARACTERISTICS

<i>Inputs:</i>	Four low level microphone inputs and two high level line inputs, any combination of four being available at any one time; incorporating high level mixing.
<i>Input Impedance:</i>	Microphone: 200 ohm non-terminating; Line: 100K ohms unbalanced bridging (20K ohm balanced line with optional plug-in transformer).
<i>Outputs:</i>	Two 1 volt normal output level; 30 volts maximum output level when fed to a bridging input with an input impedance of at least 100K ohms. Cable capacity should not exceed 0.001 microfarad to preserve high frequency response.
<i>Gain:</i>	Sufficient to produce a 1 volt output with an input signal of -65 dbm on any microphone channel and -20 dbm on any line channel for maximum control settings.
<i>Frequency Response:</i>	± 1 db 40 to 15,000 cycles per second.
<i>Noise:</i>	65 db below signal for inputs of -55 dbm. This represents a noise equivalent to an input signal of -120 dbm.
<i>Distortion:</i>	Microphone Preamplifier: (distortion characteristics as a function of input level) 30 cycles— Less than 0.2% at -52 dbm input level Less than 0.4% at -42 dbm input level Less than 1.0% at -32 dbm input level 500 to 15,000 cycles— Less than 0.1% at -53 dbm input level Less than 0.3% at -43 dbm input level Less than 1.0% at -29 dbm input level Line Output: (distortion characteristics—at nominal gain—as a function of output level) 30 cycles— Less than 0.2% at 1 volt output level Less than 0.4% at 10 volt output level Less than 1.0% at 25 volt output level 500 to 15,000 cycles— Less than 0.3% at 25 volt output level
<i>Crosstalk Rejection:</i>	65 db at 500 cycles, 50 db at 10KC.
<i>Controls:</i>	Four Allen-Bradley potentiometers (calibrated step type available on special order); master gain (two gang) potentiometer; key switches for selection of microphone or line on two input positions; key switches for channel A, both or channel B on each mixer position; ac line switch; mixer coupling switch (located on the back of the chassis).
<i>Connectors:</i>	Cannon "XL" type on all input and outputs except for a terminal strip used for mixer coupling.
<i>Power Input:</i>	105-125 volts, 50-60 cycles, 30 watts.
<i>Tubes:</i>	Six EF86/6267's and one 12AU7.
<i>Dimensions:</i>	5 - 7/32" H, 19" L, and 5 - 3/16" D (for 5 - 1/4" rack space or portable case).
<i>Accessories:</i>	Plug-in 20K ohm balanced bridge line input transformer (Catalog No. 96134-01).

EQUIPMENT APPLICATIONS

The MX-35 Mixer Assembly is a compact, flexible speech input system that has numerous applications in the tape recording and sound reinforcing fields. In the tape recording field, when used with a professional quality recorder such as the Ampex Model 354 or 351, applications include: the recording of live program material, both stereophonic and monophonic; and the dubbing of live program material over previously recorded material, both stereophonic and monophonic. In the sound reinforcing field, the mixer assembly can be used to advantage in plant paging systems and in public address or sound reinforcing

STEREO RECORDING (LIVE)

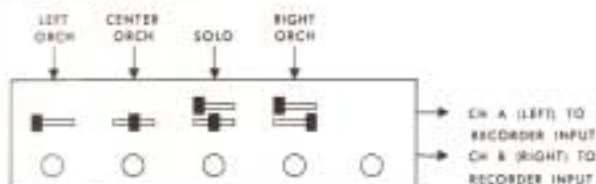

STEREO RECORDING (DUBBING)

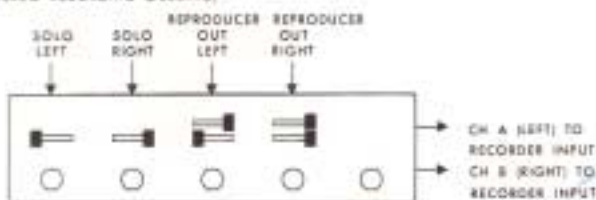

MONOPHONIC RECORDING (LIVE)

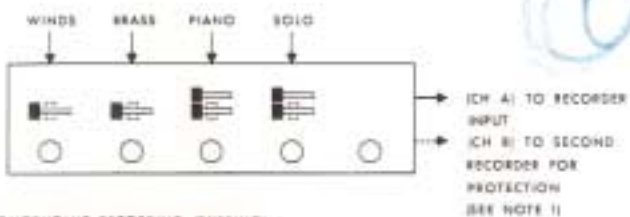

MONOPHONIC RECORDING (DUBBING)

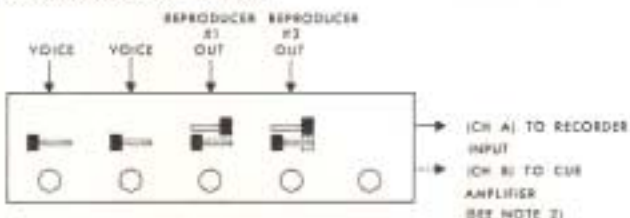

NOTES:

1. IF A SECOND "PROTECTION" RECORDING IS DESIRED, THE "CH A-BOTH-CH B" SWITCHES SHOULD BE IN THE "BOTH" POSITION.
2. REPRODUCER #2 CAN BE "CUE'D" WHILE RECORDING FROM OTHER INPUTS BY SWITCHING "CH A-BOTH-CH B" SWITCH TO "CH B"

Typical uses of the MX-35 mixer

installations because it permits great flexibility of switching and channel combinations. The following paragraphs and illustrations are intended to show some of the basic applications.

For the stereo recording of a live program, one basic set-up is to connect four microphones to the mixer and, using the channel selector switches, feed the "left" microphone to Ch. A, the "center" and "solo" microphones to both channels, and the "right" microphone to Ch. B.

For dubbing live stereo program material over a previously recorded stereo program, one basic set-up is to connect two microphones to microphone inputs 1 and 2 of the mixer and the outputs of a stereo tape reproducer to line inputs 1 and 2. Using the channel selector switches, feed the "left" microphone and the "left" line to Ch. A and feed the "right" microphone and the "right" line to Ch. B.

The basic set-up for monophonic recording of a live program is similar to the set-up described for stereo, the basic difference being that all microphones are fed to Ch. A only (or to both channels when making a second simultaneous "protection" recording).

All of the above applications have considered only one mixer assembly and only one or two channel operation. Still considering one or two channel operation, two or more mixer assemblies (up to four) can be "coupled" together to provide additional inputs. Further, two or more mixer assemblies can be "stacked" together (without coupling) to provide additional channels (up to four channels can be provided with only two mixer assemblies). Finally, mixer assemblies can be both "coupled" and "stacked" in almost any combination desired. All of these applications are, of course, only basic and many variations are possible limited only the user's imagination and skill.

NOTE

The coupling switch transfers the output of Ch. A and the output of Ch. B from the SINGLE MIXER NORMAL to the MIXER COUPLE condition simultaneously, therefore the channels of one mixer cannot be coupled to the channels of another mixer separately.

INSTALLATION

GENERAL

The MX-35 Mixer Assembly is shipped mounted in a portable case after a thorough inspection and performance check at the factory. In the event that the equipment is requested disassembled for custom installation, all assembly hardware is provided.

The portable version of the mixer is shipped ready to operate except for the connection of interconnecting cables, thus the two installation paragraphs immediately following can be bypassed.

INSTALLATION OF EQUIPMENT

When the mixer assembly is to be custom installed, the equipment can be mounted on a standard 19-inch relay-type rack. Mounting dimensions for the mixer assembly are shown in the accompanying illustration.



MX-35 mixer assembly — ¾ view

INSTALLATION OF PLUG-IN ITEMS

Only one plug-in item is available for the mixer assembly, the balanced bridge line input transformer (Catalog No. 96134-01). When the transformer is to be used, it should be plugged into socket J7S and/or J8S.

If the transformer is *not* used, the dummy plug (Catalog No. 17420-01), which is supplied with the equipment, *must* be plugged into socket J7S and/or J8S.

CONNECTIONS

Connect the power cable from the a-c power input connector, J12P, on the mixer assembly to a convenient 117 volt a-c power

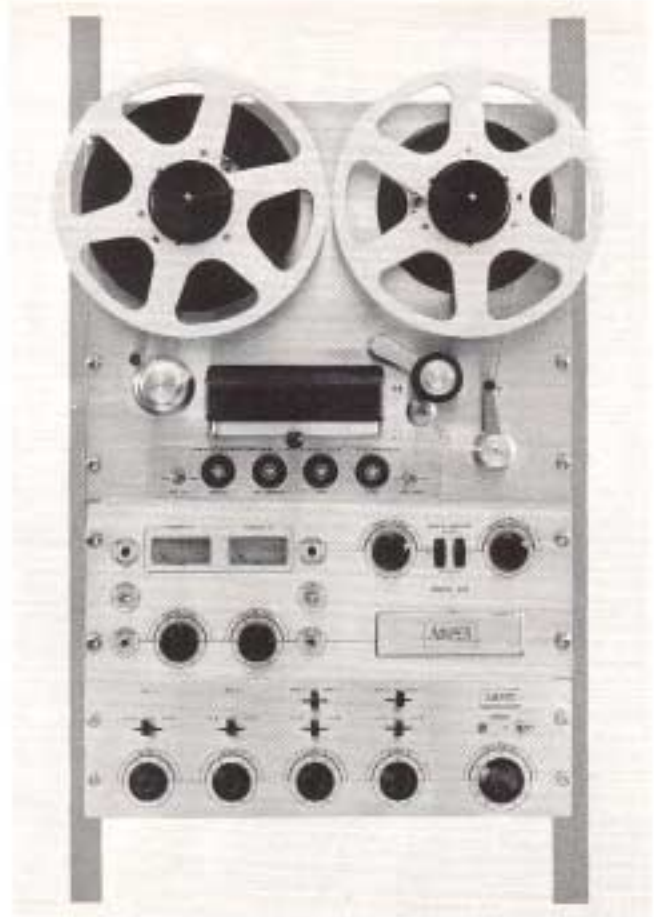

Rack layout (shown with Ampex 354 tape recorder)

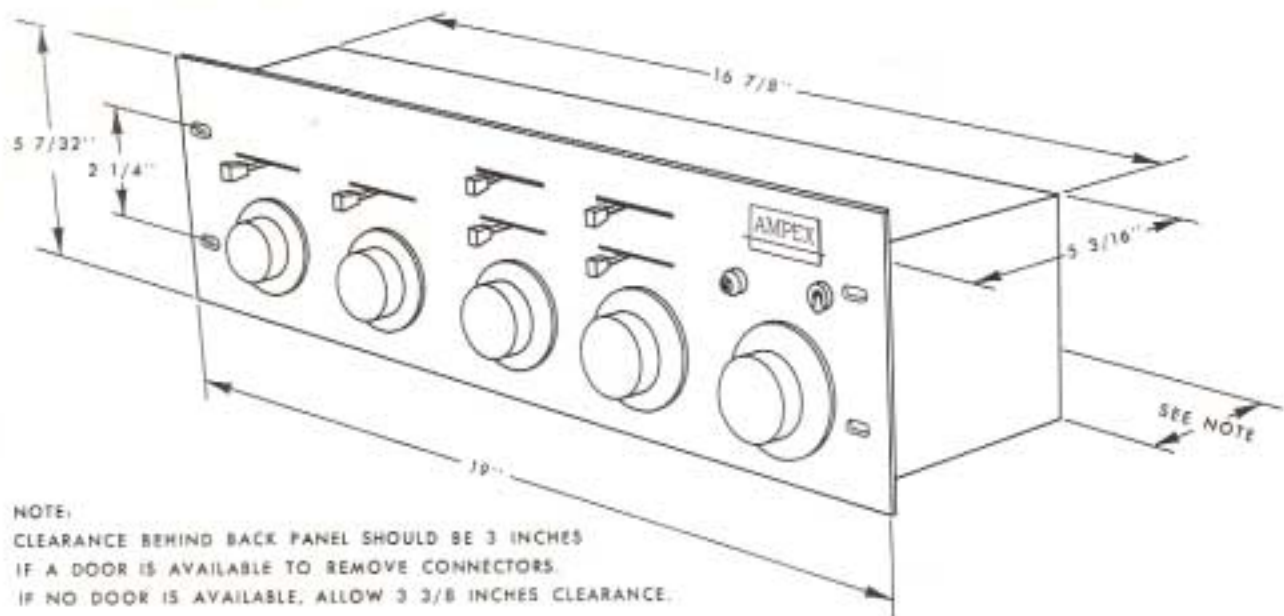

NOTE:
 CLEARANCE BEHIND BACK PANEL SHOULD BE 3 INCHES
 IF A DOOR IS AVAILABLE TO REMOVE CONNECTORS.
 IF NO DOOR IS AVAILABLE, ALLOW 3 3/8 INCHES CLEARANCE.

Mounting dimensions

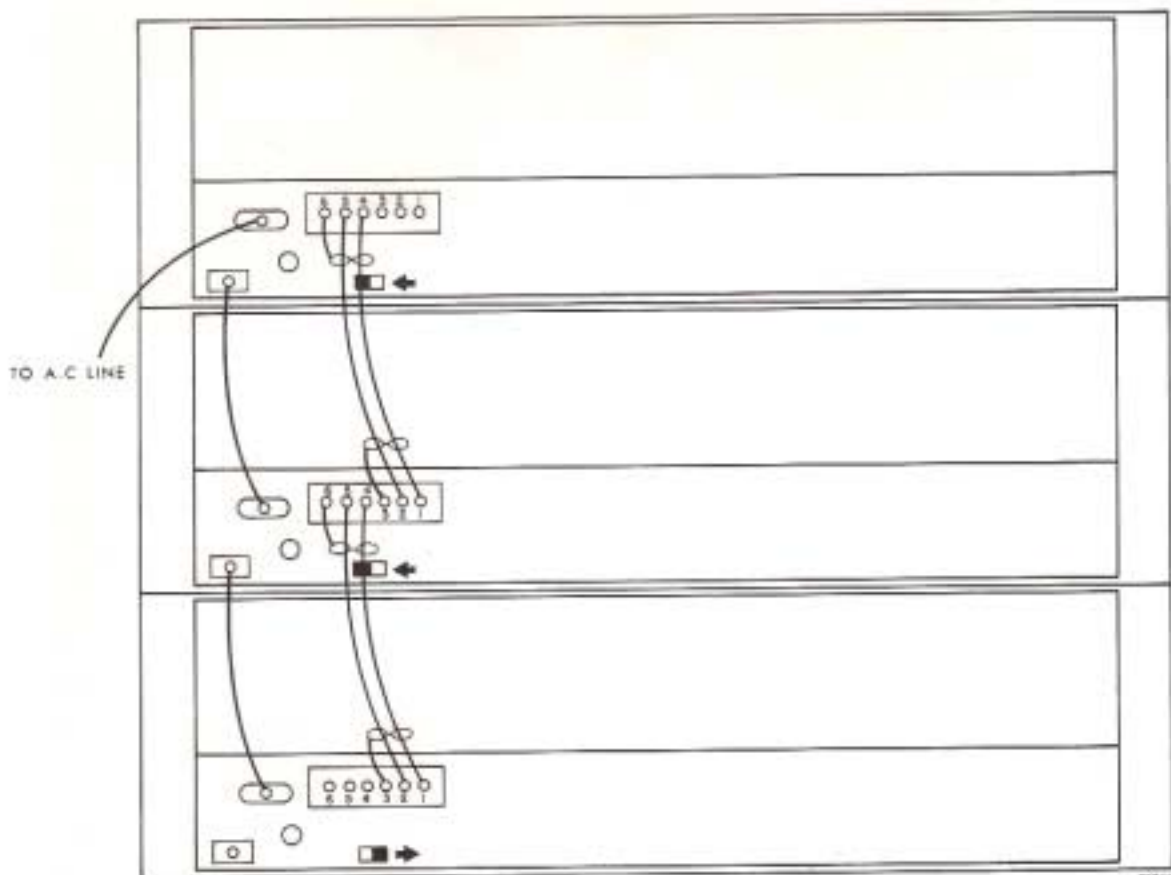

Interconnecting two or more mixers

source. Connect the OUTput connectors, J9P and J10P, of the mixer to the input connectors of the equipment with which the mixer assembly is to be used.

If more than four inputs are required, additional mixers must be used. In this case, the coupled mixer terminal strip TS1 (pins 4, 5 and 6) of the *first* mixer should be connected to the coupled mixer terminal strip TS1 (pins 1, 2 and 3) of the *second* mixer and the coupled mixer terminal strip TS1 (pins 4, 5 and 6) of the *second* mixer should be connected to the coupled mixer terminal strip TS1 (pins 1, 2 and 3) of the *third* mixer, etc. The OUTput connectors of the *last* mixer should be connected to the user's equipment. The coupled mixer switch, S7, on the rear of each of the mixers, *except the last one*, should be in the MIXER COUPLE position. The coupled mixer switch on the last mixer should be in the SINGLE MIXER NORMAL position. When two or more mixers are coupled together in this manner, there are still *only two outputs* and the "master gain" control on the *last* mixer

assembly controls overall gain while all other "master gain" controls become inoperative.

If more than two outputs are required (i.e., 3 channel operation), additional mixers are also required. In this case, however, the mixers are *not* coupled together as previously described, but rather, each mixer is connected as described for single mixer operation.

Connect the inputs (lines and/or microphones) to the mixer(s) as desired.

NOTE

The MX-35 Mixer Assembly is specifically designed for use with the Ampex Model 354 Tape Recorder/Reproducer. Use of the mixer is, however, not limited to this tape recorder. The mixer may be used with any electronics equipment that has an input impedance of at least 100,000 ohms and requires 1 volt rms input or less for proper operation. Cable capacity should not exceed 1000 μ mf to preserve high frequency response.

OPERATING INSTRUCTIONS

CONTROLS

On the front panel of the mixer assembly are facilities for setting the levels of the individual inputs and the combined outputs. Switching allows each input to be fed to either or both outputs and additional switching allows the selection of either mike or line input in the No. 3 and No. 4 mixer position. All switching regardless of combination maintains proper balance and isolation between channels.

The following table describes the function of each operating control. All controls listed are on the front panel of the mixer unless otherwise noted.

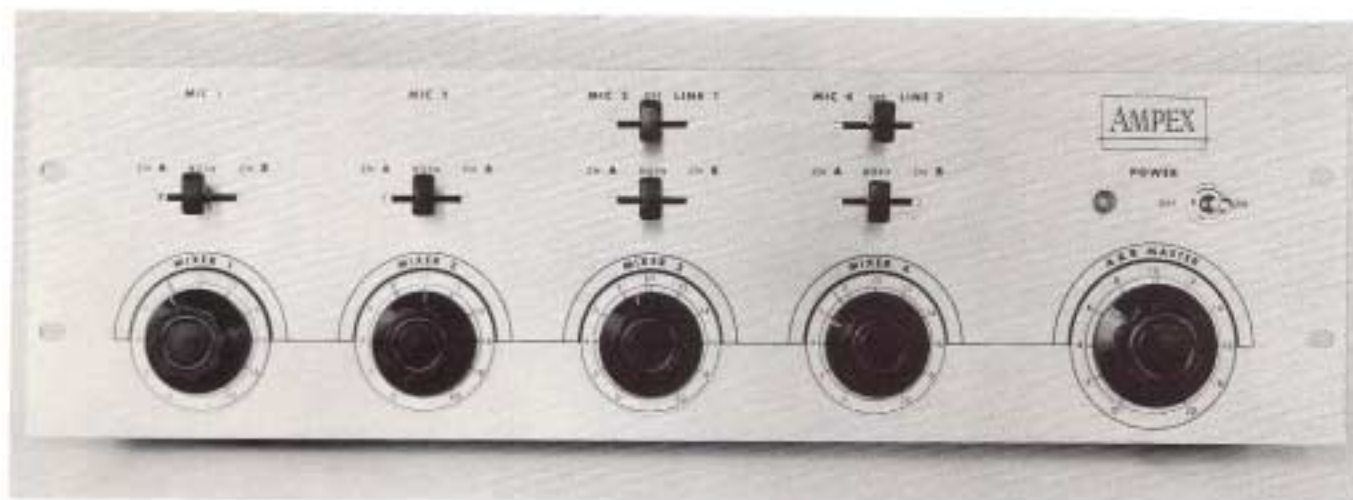

Operating controls

Item	Reference Symbol	Function
POWER ON-OFF SWITCH	S8	Controls power to the mixer assembly. Indicator lamp DS1 is lit when power is ON.
MICROPHONE-LINE SWITCH	S1 S2	Used to select Microphone 3 or LINE 1 (switch S1) and Microphone 4 or LINE 2 (switch S2). When in the center (OFF) position, no output is obtained from that mixer position.
CH. A - CH. B SELECTOR SWITCH	S3 S4 S5 S6	Used to feed the input to either or both of the outputs.
MIXER LEVEL	R5 R10 R15 R21	Adjusts the level of the individual inputs.
A & B MASTER LEVEL	R53	Adjusts the level of the combined inputs.
COUPLED MIXER SWITCH	S7 (rear panel)	Allows two or more mixer assemblies to be coupled together.
LEVEL SET	R32 (Chassis) R36 (sis)	Adjusts the overall gain and balance of the mixer assembly.

APPLYING POWER

Power is supplied through POWER switch S8 which must be turned on to operate the mixer assembly. If more than one mixer assembly is used, the POWER switch on each mixer must be turned on. The mixer assembly is fused by the $\frac{3}{4}$ ampere fuse F1.

SETTING UP THE CONTROLS

NOTE

To avoid overloading the user's equipment, the gain controls should ALL be turned to 0 (maximum counterclockwise rotation) before starting the following procedure.

Set the gain controls on the associated equipment to approximately 3 o'clock. Set the channel selector and MICROPHONE-LINE selector switches on the mixer as desired. Set the A & B MASTER gain control on the mixer assembly to approximately 12 on the dial. Turn the individual MIXER gain controls to provide sufficient signal strength and proper balance, taking care that the combined inputs do not overload the associated equipment.

When a high output level microphone (-30 dbm or higher) is used, it is preferable to turn down the individual MIXER gain controls rather than the A & B MASTER gain control.

Turn the associated reset dials on the mixer assembly to the corresponding position for the control concerned so that the gain controls may be turned down and then returned to the same volume (as with fading in or out).

OPERATION OF THE EQUIPMENT

After the controls and reset dials have been set as outlined in the preceding paragraph, operation consists of varying the controls (around the gain indicated by the reset dials) in accordance with the program material. Beyond these operating instructions, operation is a matter of personal preference and proficiency.

CHECKOUT AND ADJUSTMENT

GENERAL

In the following checkout and adjustment procedures, each input and each channel should be treated separately. That is, check microphone 1 input through channel A first, then microphone 1 input through channel B followed by microphone 2 input through channel A, etc. The sequence (which input and which channel is checked first) is unimportant.

Test equipment required for proper checkout and adjustment consists of an ac vacuum tube voltmeter capable of indicating rms voltages of 0.004 or less (Hewlett-Packard Model 400D or equivalent) and an audio oscillator with stable output from 50 cps to 15KC (Hewlett-Packard Model 200A or equivalent).

OVERALL GAIN MEASUREMENT

With all front panel level controls set at maximum and with the LEVEL SET controls (screwdriver adjust) set at their nominal positions, a 1.0 volt output is achieved with a -55 dbm microphone input or with a -10 db line input. Because the db scale of the Hewlett-Packard Model 400D is calibrated with respect to a reference level of one milliwatt into 600 ohms and the nominal characteristic input impedance of the microphone preamplifiers is 200 ohms (a difference of 5 db), the gain from the microphone input *appears* to be 60 db using the test set-up illustrated.

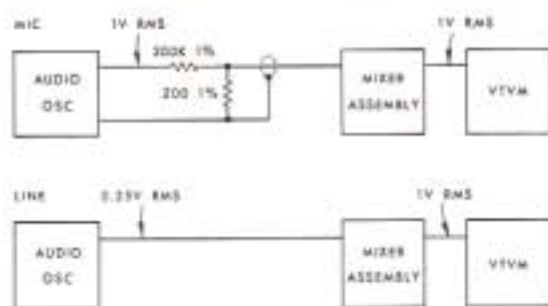

Response and gain measurement set-up

NOTE

There is an adjustment of ± 10 db from this nominal gain and if a different setting of the LEVEL SET controls is used, the input and/or output levels shown on the test set-up illustration will have to be modified accordingly.

- Step 1:** Connect the audio oscillator and the vtvm as shown in the test set-up. Set the oscillator at 500 cps.
- Step 2:** Set all front panel level controls at maximum.
- Step 3:** Set the oscillator output level at 1 volt rms for the microphone input or 0.25 volt rms for the line input. Output of the mixer assembly should be 1 volt rms as read on the vtvm. (See note above.)

OVERALL GAIN ADJUSTMENT

To set the overall gain of the mixer assembly to the nominal value (or any other value

within 10 db of the nominal), use the following procedure.

- Step 1:** Connect the audio oscillator and the vtvm as shown in the test set-up. Set the oscillator at 500 cps.
- Step 2:** Set all front panel level controls at maximum.
- Step 3:** Set the oscillator output level at 1 volt rms for the microphone input or 0.25 volt rms for the line input. (See NOTE in the GAIN MEASUREMENT paragraph.)
- Step 4:** Adjust the LEVEL SET control to produce a 1 volt rms output as read on the vtvm. (See NOTE in the GAIN MEASUREMENT paragraph.)

FREQUENCY RESPONSE MEASUREMENT

- Step 1:** Connect the audio oscillator and the vtvm as shown in the test set-up. Set the oscillator at 500 cps.
- Step 2:** Set all front panel level controls at maximum.
- Step 3:** Set the oscillator output level at 1 volt rms for the microphone input or 0.25 volt rms for the line input (or to the value used in setting the gain in the GAIN ADJUSTMENT paragraph).
- Step 4:** Make a frequency response check by using at least ten discrete frequencies between 30 and 15,000 cps. The output level of the mixer assembly should not vary more than plus or minus one db from the normal output.

MAINTENANCE AND TROUBLESHOOTING

GENERAL MAINTENANCE INFORMATION

Careful periodic performance checks will ensure excellent equipment operation. When the system is set up according to the instructions in this manual, equipment performance should meet the high Ampex standards.

CORRECTIVE MAINTENANCE

The first step in any corrective maintenance procedure is localizing the faulty circuit. A run through of the alignment and performance checks of the mixer assembly will help isolate the trouble and the faulty component then should be easily identifiable. A circuit for trouble shooting the mixer after the performance checks have been made (especially use-

ful if the trouble has not been isolated) is shown below (see also—PARTS LOCATION-MIXER ASSEMBLY, and SCHEMATIC DIAGRAM-MIXER ASSEMBLY).

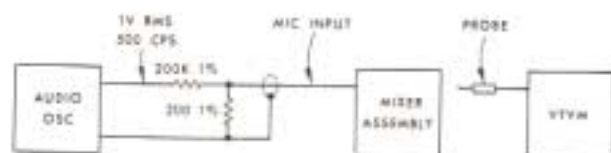

Troubleshooting the mixer

Disconnect any input or output when using this circuit. Using a vtvm probe and working back from the output toward the input, check at the grid and plate of each stage until a signal is indicated on the vtvm. The trouble then is probably in the stage immediately following that point. When the faulty stage is located, the individual components can be isolated by a check of resistance and voltages. Typical voltage readings are shown on the foldout schematic diagram; voltages measured will vary with line voltage, the voltages indicated on the schematic diagram were measured with a 117 volt line voltage.

ORDERING PARTS

The purpose of the parts list is to aid the user in ordering replacement parts. Ampex

can offer fast and efficient service in providing normally replaceable parts of the components in the system when proper information is furnished. Parts are listed according to the schematic reference symbol, a description of the part, and the Ampex part number. The Ampex Corporation offers some replacement parts that are not necessarily exact replicas of those used in the original version of the equipment; but these parts are interchangeable with the original parts. The description column names the part, its composition, electrical value and manufacturer's number (or military specification when available)—and the AMPEX PART NUMBER.

Ampex part numbers are the exact designation for all parts used in Ampex equipment. For example: CAPACITOR, fixed; ceramic, $0.02\mu f$ +80% -20%, 500 vdcw; Sprague Part No. 36C205 will always bear the Ampex Catalog Number 030-059. **THIS IS THE NUMBER THAT SHOULD BE USED WHEN ORDERING REPLACEMENT PARTS.** The schematic reference number should NOT be used for ordering parts as the part value may vary with different equipment types. Include the following information when ordering parts: Equipment Type, Equipment Serial Number, Ampex Part Number, and Description of Part. Example: 4 ea. 030-059 capacitors for Model MX-35 Mixer Assembly.

MODEL MX-35 MIXER ASSEMBLY PARTS LIST

Catalog Number 96910-01

REF. NO.	PART DESCRIPTION	AMPEX PART NO.
C1	CAPACITOR, Mylar: 0.33 ufd, $\pm 10\%$, 400 vdcw; Goodall Part No. Type 623	035-957
C2	CAPACITOR, Electrolytic: 50 ufd, -10% $+250\%$, 6 vdcw; Sprague Part No. TVA1100	031-123
C3	CAPACITOR, Electrolytic: 4 x 10 ufd, -10% $+50\%$, 450 vdcw; Mallory Part No. FP-434	031-077
C4	Same as C1	035-957
C5	Same as C2	031-123
C6	Same as C1	035-957
C7	Same as C2	031-123
C8	Same as C1	035-957
C9	Same as C2	031-123
C10	CAPACITOR, Ceramic: 0.05 ufd, -20% $+80\%$, 500 vdcw; Sprague Part No. 5HK-55	030-031
C11	Same as C10	030-031
C12	CAPACITOR, Electrolytic: 20-10-10/450v, 40/250v	96077-01
C13	CAPACITOR, Electrolytic: 40 ufd, $\pm 10\%$, 250 vdcw; Sprague Part No. TVL1519	031-161
C14	CAPACITOR, Mylar: 0.1 ufd, $\pm 10\%$, 400 vdcw; Cornell Dubilier Part No. WMF4P1E	035-999
C15	Same as C14	035-999
C16	CAPACITOR, Mylar: 0.47 ufd, $\pm 20\%$, 400 vdcw; Cornell Dubilier Part No. WMF4P47E	035-981
C17	Same as C16	035-981
C18	CAPACITOR, Electrolytic: 2000 ufd, -10% $+250\%$, 15 vdcw; Mallory Part No. WP-041	031-085
C19	CAPACITOR, Paper: 0.0047 ufd, $+20\%$, 600 vdcw; Sprague Part No. 73P47206	035-028
C20	Same as C19	035-028
CR1	DIODE, Crystal: diffused silicon, 600 volts, P.I.V.; Texas Instrument Part No. 1N2071	013-995
CR2	Same as CR1	031-995
CR3	RECTIFIER, Selenium: Radio Receptor Part No. C1181C1E1G	582-898

REF. NO.	PART DESCRIPTION	AMPEX PART NO.
DS1	LAMP, Neon: clear: Eldema Part No. 1B95277	060-996
F1	FUSE, Cartridge: 1/4 x 1-1/4, 0.75 amps, slow-blow, 125v: Littlefuse Part No. 313.750	070-048
J1S	CONNECTOR, Receptacle: female, 3 contact, Cannon Part No. XLR-3-31	146-998
J2S	Same as J1S	146-998
J3S	Same as J1S	146-998
J4S	Same as J1S	146-998
J5S	Same as J1S	146-998
J6S	Same as J1S	146-998
J7S	SOCKET, Octal: mica: Cinch Part No. 12272 8 AM	150-010
J8S	Same as J7S	150-010
J9P	CONNECTOR, Receptacle: male, 3 contact: Cannon Part No. XLR-3-32	147-999
J10P	Same as J9P	147-999
J11S	CONNECTOR, Receptacle: female, 2 contacts: Circle F Part No. M-438	146-999
J12	CONNECTOR, Receptacle: male, 2 contact: Tower Part No. C10610A	147-032
R1	RESISTOR, Fixed: carbon, 22K ohms, 1/2 watt, 10%: MIL-R-11:RC20GF223K	041-064
R2	RESISTOR, Fixed: carbon, 1.5K ohms, 1/2 watt, 10%: MIL-R-11:RC20GF152K	041-050
R3	RESISTOR, Fixed: film, 47K ohms, 1 watt, 1%, Dalohm Type DC-1	042-049
R4	RESISTOR, Fixed: carbon, 10K ohms, 1/2 watt, 10%, MIL-R-11:RC20GF103K	041-060
R5	RESISTOR, Variable: carbon, 100K ohms, 2 watt, 10%: Allen Bradley Part No. JAIN056S104AZ	044-015
R6	Same as R1	041-064
R7	Same as R2	041-050
R8	Same as R3	042-049
R9	Same as R4	041-060
R10	Same as R5	044-015
R11	Same as R1	041-064
R12	Same as R2	041-050
R13	Same as R3	042-049

REF. NO.	PART DESCRIPTION	AMPEX PART NO.
R14	Same as R4	041-060
R15	Same as R5	044-015
R16	RESISTOR, Fixed: carbon, 1.2 megohm, 1/2 watt, 10%, MIL-R-11:RC20GF125K	041-084
R17	Same as R1	041-064
R18	Same as R2	041-050
R19	Same as R3	042-049
R20	Same as R4	041-060
R21	Same as R5	044-015
R22	Same as R16	041-084
R23	RESISTOR, Fixed: carbon, 330K ohms, 1/4 watt, 5%: Allen Bradley Type C-B	041-932
R24	Same as R23	041-932
R25	Same as R23	041-932
R26	Same as R23	041-932
R27	Same as R23	041-932
R28	Same as R23	041-932
R29	Same as R23	041-932
R30	Same as R23	041-932
R31	RESISTOR, Fixed: carbon, 220K ohms, 1/2 watt, 10%: MIL-R-11:RC20GF224K	041-076
R32	RESISTOR, Variable: carbon, 1 megohm, .3 watt, ±20%: Chicago Telephone Type PE-200	044-993
R33	RESISTOR, Fixed: carbon, 8.2K ohms, 1/2 watt, 10%: MIL-R-11:RC20GF822K	041-059
R34	RESISTOR, Fixed: wirewound, 1.5K ohms, 1 watt, 5%: IRC Type EW-1	043-989
R35	Same as R31	041-076
R36	Same as R32	044-993
R37	Same as R33	041-059
R38	Same as R34	043-989
R39	RESISTOR, Fixed: carbon, 3.9K ohms, 1 watt, 10%: MIL-R-11:RC32GF392K	041-153
R40	RESISTOR, Fixed: carbon, 4.7K ohms, 1/2 watt, 10%: MIL-R-11:RC20GF472K	041-056
R41	RESISTOR, Fixed: carbon, 100K ohms, 1/2 watt, 10%: MIL-R-11:RC20GF104K	041-072

REF. NO.	PART DESCRIPTION	AMPEX PART NO.
R42	Same as R40	041-056
R43	Same as R39	041-153
R44	RESISTOR, Fixed: carbon, 2.2K ohms, 2 watt, 10%: MIL-R-11:RC43GF222K	041-205
R45	RESISTOR, Fixed: carbon, 240K ohms, 1/2 watt, 5%: MIL-R-11:RC20GF244J	041-374
R46	RESISTOR, Fixed: carbon, 500K ohms, 1/2 watt, 10%: MIL-R-11:RC20GF564K	041-081
R47	RESISTOR, Fixed: carbon, 22K ohms, 2 watts, 10%: MIL-R-11:RC42GF223K	041-216
R48	RESISTOR, Fixed: carbon, 150K ohms, 1/2 watt, 10%: MIL-R-11:RC20GF154K	041-074
R49	Same as R45	041-374
R50	Same as R46	041-081
R51	Same as R47	041-216
R52	Same as R48	041-074
R53	POTENTIOMETER, Dual ganged, 25K ohms	96928-01
R54	RESISTOR, Fixed: carbon, 24K ohms, 1/2 watt, 5%: MIL-R-11:RC20GF243J	041-369
R55	Same as R54	041-369
R56	RESISTOR, Fixed: wirewound, 2 ohms, 5 watts, 10%: Tru-Ohm Type X-60	043-990
R57	RESISTOR, Fixed: carbon, 2.2K ohms, 1/2 watt, 10%: MIL-R-11: RC20GF222K	041-052
R58	Same as R57	041-052
S1	SWITCH, Mixer	96925-01
S2	Same as S1	96925-01
S3	SWITCH, Mixer	96926-01
S4	Same as S3	96926-01
S5	Same as S3	96926-01
S6	Same as S3	96926-01
S7	SWITCH, Slide: DPDT	96139-02
S8	SWITCH, Toggle: SPST: Arrow H & H Part No. 86994-N	120-005
T1	TRANSFORMER, Microphone	96908-01
T2	Same as T1	96908-01
T3	Same as T1	96908-01
T4	Same as T1	96908-01

REF. NO.	PART DESCRIPTION	AMPEX PART NO.
T5	TRANSFORMER, Power	96144-01
TS1	STRIP, Terminal: barrier, 6 terminals: Cinch Part No. 6-140Y	160-111
V1	TUBE, Electron: 9 pin, EF86/6267: Amperex	012-098
V2	Same as V1	012-098
V3	Same as V1	012-098
V4	Same as V1	012-098
V5	Same as V1	012-098
V6	Same as V1	012-098
V7	TUBE, Electron: 9 pin, 12AU7: Amperex	012-107
	INDICATOR, Reset	50735-02
	PLUG ASSEMBLY, Dummy	17420-01
	KNOB, Key tab	96922-02
	CORD, Power input	084-004
	POST, Fuse: Littlefuse Part No. 342012	085-001
	SHIELD, Tube, 9 pin: Cinch Part No. 9S2	160-012
	KNOB, Small	230-003
	KNOB, Large	230-004
	SOCKET, Tube: 9 pin: Cinch Part No. 53F12621	150-020
	MOUNTING, Capacitor: phenolic, 3 terminal: Mallory Part No. BP-4	290-026
	MOUNTING, Capacitor: phenolic, 4 terminal: Mallory Part No. BP-6	290-004
	CONNECTOR, Plug: female, 3 contacts: Cannon Part No. XL-3 11	144-003

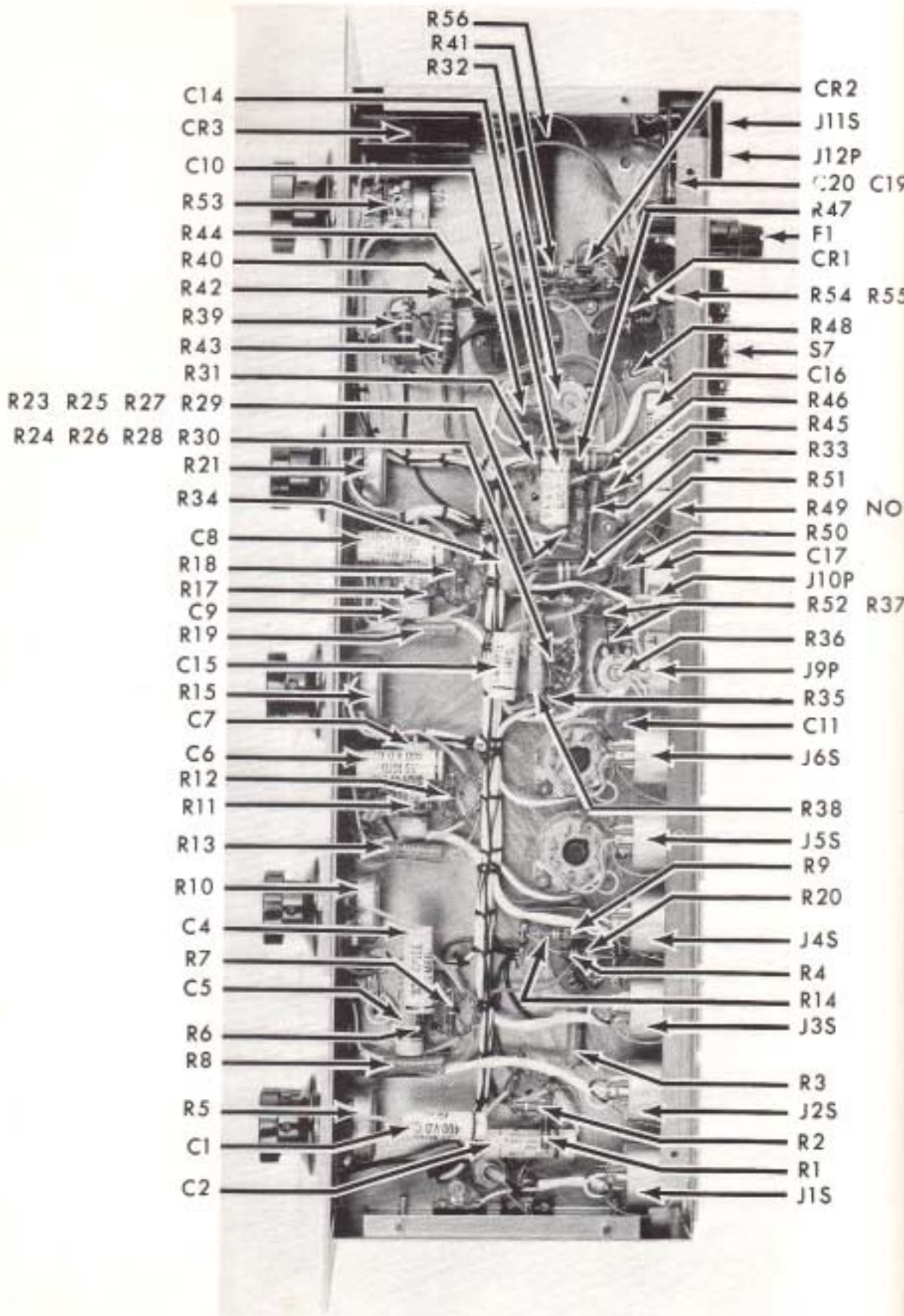

PARTS LOCATION
MX-35 MIXER

NOT SHOWN

NOT SHOWN

SHOWN

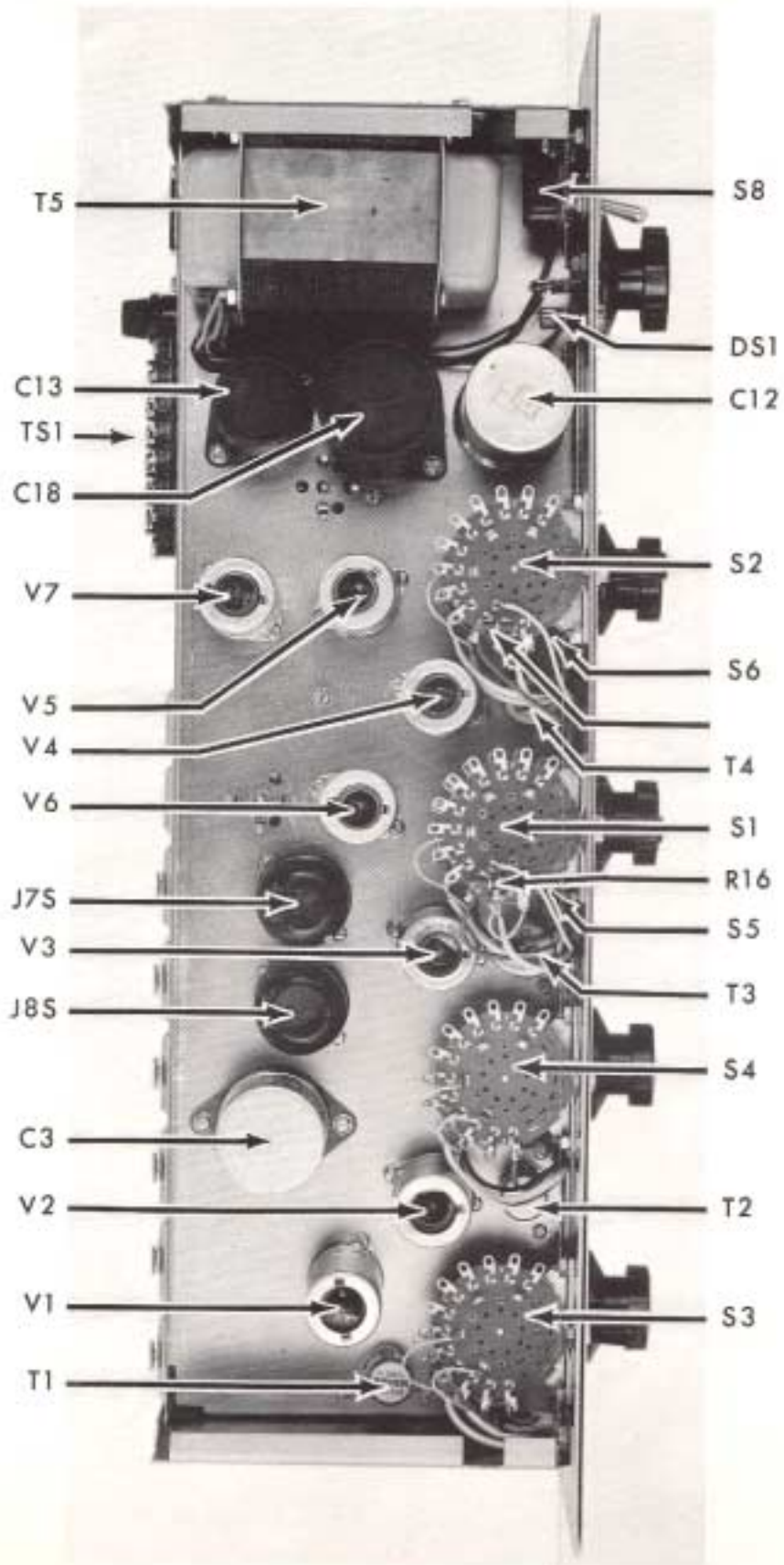

THEORY OF OPERATION

MICROPHONE PREAMPLIFIERS

Operation of the four microphone preamplifiers is identical. Each preamplifier is a high-gain low-noise, triode-connected pentode. The audio signal from a low impedance microphone is fed to the control grid of the preamplifier by the input transformer. The audio signal is amplified by the preamplifier and coupled to the gain control. In the case of a microphone/line input, switching between the microphone input and the line input takes place immediately prior to the gain control.

From the gain control, the signal is coupled to the channel selector switch for the station concerned. The channel selector is a three-position switch that connects the signal to either or both output amplifiers while maintaining correct loading and attenuation relationships.

Resistors R1, R6, R11 and R17 are used to isolate the tube input capacitance from the inductance of the secondary winding of the input transformer to yield a flat frequency response.

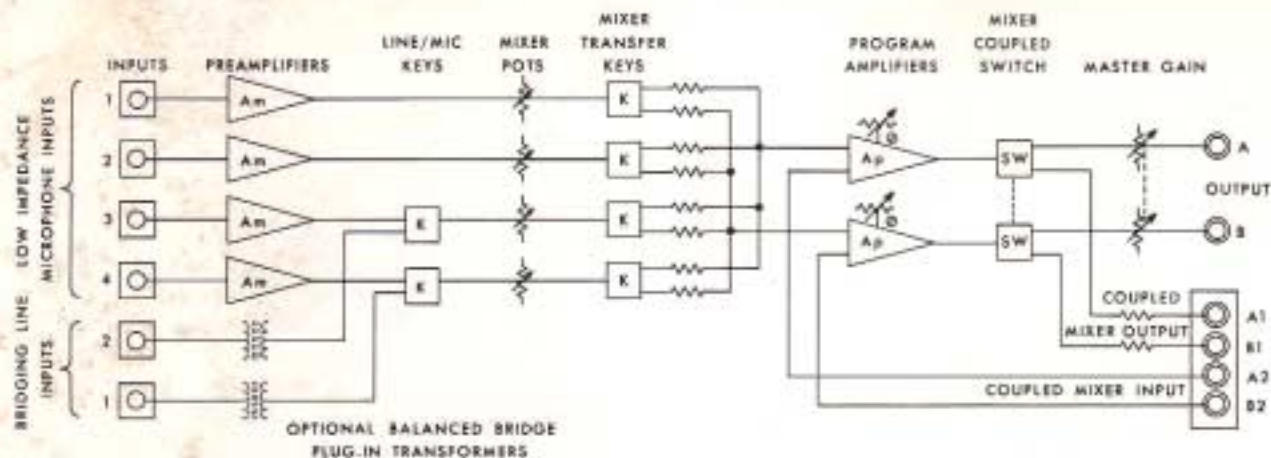

Block diagram, MX-35 mixer

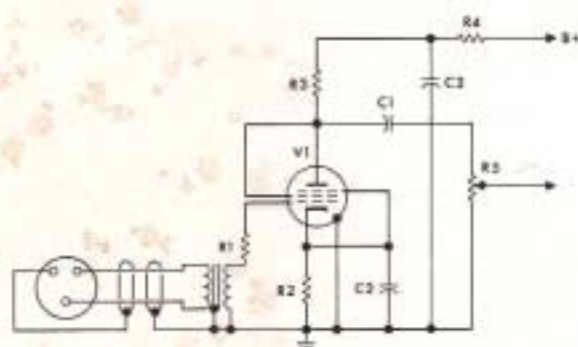

Partial schematic diagram, microphone preamplifier

OUTPUT AMPLIFIERS

The output amplifier consists of a pentode amplifier followed by a cathode follower. One of the unusual portions of the circuit is the source of the screen grid voltage for the pentode stage which is derived from the cathode of the follower stage. This provides added reliability to the circuit and helps compensate for tube aging. The plate of the pentode stage is directly coupled to the control grid of the cathode follower.

The cathode resistor of the cathode follower is interlocked to ground through the two shield connections of the pentode stage so that excessive current will not be drawn by the cathode follower when the pentode is pulled from the tube socket.

Negative feedback is applied from the cathode of the cathode follower to the control grid of the pentode stage through output capacitor C16 (C17 for channel "B"), resistor R48 (R52 for channel "B"), LEVEL SET potentiometer

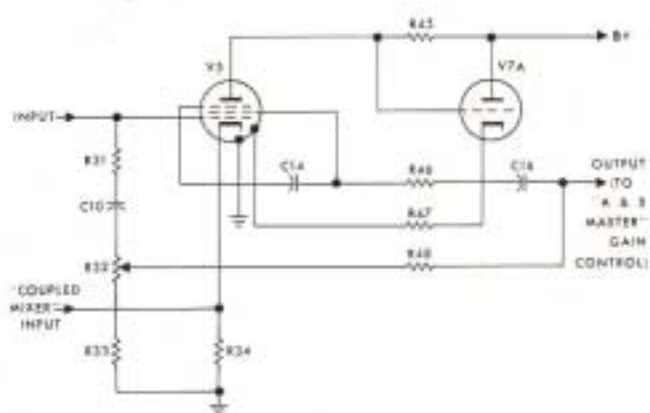

Partial schematic diagram, output amplifier

R32 (R36 for channel "B"), capacitor C10 (C11 for channel "B"), and resistor R31 (R35 for channel "B"). The negative feedback provides overall gain stability to the circuit and the LEVEL SET potentiometers control the overall gain of each channel of the mixer assembly.

MIXER COUPLING

When switch S7 is in the SINGLE MIXER NORMAL position, the output of the cathode follower is fed to the output connector through the A & B MASTER gain control, R53. When switch S7 is in the MIXER COUPLE position, the output of the cathode follower is connected to terminal strip TS1 through attenuator resistor R54 (R55 for channel "B") and when the terminal strip is connected to terminal strip TS1 of a second mixer assembly, the signal from the first mixer is attenuated and combined with the signal from the second mixer.

POWER SUPPLY

Silicon rectifiers CR1 and CR2 are used in a conventional full-wave voltage doubler rectifier circuit to supply plate power for all tubes in the mixer assembly. Selenium rectifier CR3 is connected as a conventional full-wave center tap rectifier to provide dc filament voltage for all tubes.

The center tap of the V7 tube filament provides a ground for the dc filaments. AC power input is connected at the power receptacle, J12P, and is controlled by POWER

switch S8. The power is fed through fuse F1 to the primary of power transformer T5.

There are two secondary windings on the power transformer—one for the filament supply and one for the high voltage supply. The filament winding supplies 12.6 volts dc (after rectification), to the filaments of all tubes. The high voltage supply ripple is filtered by a capacitance-input r-c filter formed by resistors R39, R40, R42, R43, and R44 and capacitors C13, C12d, C12c, C12b, and C12a; additional filtering is supplied by the decoupling networks.