

DEVELOPMENT OF A SUBJECTIVE FLUTTER MEASUREMENT STANDARD

John G. McKnight*
Ampex Corp., Research Dept.
Redwood City, California

This paper presents the history and the text of a new draft Subjective Flutter measurement standard being considered by IEEE as a replacement for the present "Flutter Content" standard (IEEE Nr. 193, ANSI Z57.1-1954). The Subjective Flutter measurement method is identical to the "weighted quasi-peak" method previously standardized by DIN (45 507, 1966) and CCIR (409-1, 1966), and now under consideration by IEC.

1. INTRODUCTION

The problem of meaningful flutter measurements for sound recording equipment is of long standing, and has been well summarized by Comerçi [1]. The flutter of a reproducer is best measured by reproducing a constant-wavelength ("flutter free") recording. The flutter (speed variations) of the reproducer frequency modulates the constant-wavelength recording. The flutter meter is a frequency-demodulator, a bandpass filter to determine the range of demodulated frequencies which will be measured, and an indicating system (Fig. 1). As Comerçi points out, the "flutter" modulation waveform is often a wide-band, noise-like signal; because of this, both the frequency response of the filter and the dynamic response of the indicator must be controlled in order to obtain the same reading from flutter meters made by different manufacturers. If the proper time- and frequency-response values are chosen, the readings will not only be consistent, but will also reflect the subjective (audible) measure of the flutter.

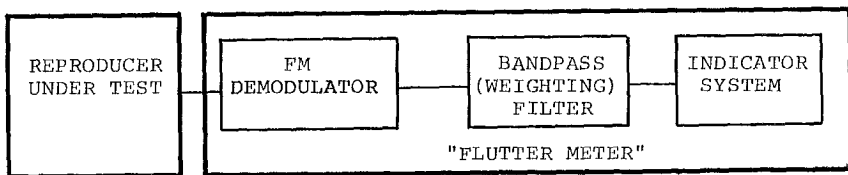

Fig. 1 Block diagram of a flutter measuring system.

*Chairman, Recording and Reproducing Standards Subcommittee, IEEE Group on Audio and Electroacoustics Standards Committee.

2. HISTORICAL REVIEW

2.1 The Present IEEE/ANSI Standard

The present IEEE and ANSI Standard [2] lacks the necessary frequency- and time-response specifications: The frequency response range is specified as 0.5- to 200 Hz, with no tolerance in this range, and no specified cutoff rate outside of this range. A note allows a cutoff at 120 Hz "except for the most critical tests". A rectifier characteristic that is "average value" or "between average and rms" is permitted, with no specification of the dynamic (time) response. A note mentions that "indicating instruments for flutter measurements should be unusually heavily damped, otherwise excessive swings are likely to occur when there is a strong flutter at slow rates, making reading difficult". But different manufacturers' opinions as to just what constitutes "unusually heavily damped" vary considerably, and several flutter meters which meet the requirements in the standard, and give the same reading on a sine-wave calibration test will often give considerably different readings when used on an actual flutter measurement of a recorder. Thus, a more detailed specification of the frequency- and time-responses is necessary for standardization.

The particular frequency response and dynamic characteristics not only must be standardized, but should also be chosen so as to give readings which correlate with the relative disturbing effect of the flutter, as judged by a listening panel. This is mentioned in an appendix entitled "Flutter Index" of the existing IEEE Standard, but this measurement has never been used widely.

2.2 The Updated "Flutter Index" Proposal

In the 1950's Frank Comerci studied the possibility of an improved "Flutter Index" measuring system. He concluded [1] that good agreement between meter readings and subjective listening panel judgements could be obtained by using a frequency-response weighting network peaking at 3 Hz, and falling at about 3 dB per octave above and below this frequency (such a response could be achieved with a passive RLC network); and, as the indicator, a Standard Volume Indicator (vu meter). The operator was instructed to note the maximum reading of the indicator, since there is often a rather large amount of needle motion ("bobbing" up and down).

This updated Flutter Index proposal was incorporated in a draft IEEE Standard Proposal in the early 1960's, but the proposal was never completed.

2.3 The 1962 DIN Standard

Several studies of subjective flutter measurement were done in Germany in the 1950's; the result of these studies is summarized in a paper by Belger, which is reprinted (in translation) as Appendix A to this preprint. This work led to a German Standard, DIN 45 507 originally issued in 1962 and revised in 1966 [3]. This method uses a weighting curve which is the average of a number of curves found by several researchers: it peaks at 4 Hz, and falls 6 dB per octave on either side (the response can be achieved by a pair of simple RC networks). The indicator reads the peaks in a controlled time interval, as does Comerchi's "Flutter Index" meter. But, rather than having the operator do the integration visually the DIN does it by using a "quasi-peak" rectifier circuit having an integrating circuit whose charging time constant is about 30 ms, and discharging time constant is about 1 s.

2.4 The 1965 NAB Standard

When the NAB Magnetic Recording Standards were being rewritten in 1962 to 1964, the Committee (C.J. LeBel and the author) considered Comerchi's "Flutter Index" proposal, and the DIN Standard. These two methods are quite similar, but unfortunately not identical. The Committee did not feel that Comerchi's experimental data justified using the more complicated RLC weighting network; instead they chose the DIN curve which can be realized with the simple RC networks.

Both of the methods used indicator systems which read the maximum value of the flutter occurring for intervals of at least 50- to 200-ms, rather than the "unusually heavy damping" of the present IEEE Standard. At the time of the NAB Committee's decision, however, the details of the circuit for the DIN method were unavailable, and it was felt undesirable to standardize on a system which might be excessively complicated and expensive. Therefore the vu meter used by Comerchi was chosen instead. Thus, the "weighted flutter" measurement of the 1965 NAB Standard [4] is a combination of the DIN weighting curve and the Comerchi vu-meter indicator.

3. THE NEW IEEE DRAFT STANDARD

3.1 Development

Subsequent field experience with the NAB flutter measurement method showed that it is satisfactory for laboratory purposes where only one carefully trained operator takes all of the flutter readings. It is very helpful if he not only reads the meter, but also listens to the tone being fed into the flutter meter, because he hears that an audible flutter is producing the "bobbing" of the flutter meter needle.

For general purposes, however--with technicians who make only occasional flutter measurements, and with production-line workers etc., none of whom usually listens to the signal--this system has proven unsatisfactory. The meter "bobs" over a 2:1 to 3:1 range, requiring altogether too much operator training and individual interpretation of the pointer motions. For this reason NAB flutter meter users have demanded that the flutter meter manufacturers add a "slow" or "damped" position on the "NAB" flutter meter. This "damping" (a large capacitor across the meter) completely negates the dynamic requirements of the NAB Standard: large flutter peaks which are very audible are damped out. This is thus a completely unsatisfactory solution if the flutter reading is to represent the subjective aspect of measurements.

This suggested to the IEEE Committee a re-evaluation of the indicator used in the DIN Standard. By this time information about the circuits used for the DIN flutter meter was available, as well as experience in the USA with the design of flutter meters conforming to the DIN Standard. This experience showed that the circuitry required is rather simple. Also, since the dynamics of the DIN meter are largely controlled by the electronic circuitry rather than by the indicating meter (microammeter) itself, the indicator required is less expensive than the vu meter required in the NAB Standard. Thus, the NAB Committee's earlier fears of complication and high cost for the DIN meter were proven groundless.

Therefore a number of "user tests" were performed on commercial flutter meters which are according to the German Standard (DIN) to find out: (1) do the DIN meter readings actually agree with subjective flutter judgments by listening panels? (2) are the DIN meters in fact easier to read than the NAB meters? and (3) are the DIN meters generally acceptable to recording equipment manufacturers and recording studios in the USA?

The first test was performed for us by Mr. A. L. Seligson of Consumers Union. CU had been using the Comerci "flutter index" method, and had verified that these readings did agree well with their tests using listening panels. They compared the DIN and "flutter index" readings with judgments by a listening panel, and found that the three readings did agree reasonably well.

The second test--ease of reading--was performed by Mr. Don Truax (then of Ampex Quality Audit) who made flutter measurements on a number of tape recorders, using both the NAB and the DIN methods. He found that the DIN reading was in fact much more easily determined, since the needle is relatively still. Several technicians' opinions were asked, and all agreed that the DIN reading was much more easily determined, and that they could easily agree on "the" reading by the DIN method. Simultaneous NAB readings by several operators were not usually in agreement because of differences in interpretation.

Thirdly, we sent a questionnaire to about 20 US tape recorder manufacturers and recording studios who were known to own DIN flutter meters. Eleven replies were received, all but one indicating satisfaction with this style of instrument. All but one said they would be in favor of changing the US flutter standard to the DIN Standard.

Because all of these tests were favorable, a draft IEEE Standard has been prepared to replace the existing IEEE and ANSI Standard. This draft standard is reproduced as Appendix B, and readers' comments are solicited. This draft is an adaptation of a draft IEC recommendation [5]. The technical requirements for the flutter meter, and the essence of the measuring procedures are the same for the DIN Standard, the IEC draft, the IEEE draft, and the current CCIR Standard [6]. Thus, there is hope for internationally uniform equipment and procedures for subjective flutter measurement.

3.2 Circuitry For The Subjective Flutter Meter

The requirements for the subjective flutter meter (Appendix B, Secs. 5 and 6) are given in terms of frequency response and time response, rather than in terms of basic circuit parameters. This is to allow the use of any of several possible circuit realizations: The frequency-response weighting can be RC or RLC, active or passive. The meter time-response is determined by both the electrical circuit and by the electromechanical parameters of the indicating meter. A few general pointers, however, will assist those first attempting to design equipment to this draft standard.

The fm demodulator requires the usual means to avoid interference by amplitude modulation of the signal, and/or noises added to the signal. Thus, automatic gain control and/or limiters, and signal bandpass (to eliminate out-of-band noise) are usually required. The demodulator may be of any of the fm detectors--pulse counter, slope detector, Foster-Seeley or ratio detector, to name a few of the common circuits.

The frequency weighting response may be achieved by a simple RC network as shown in Fig. 2. A further 6 dB per octave slope at low frequencies is required, for a total fall of at least 12 dB per octave.

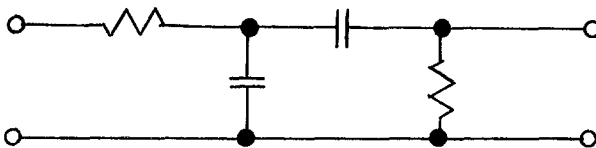

Fig. 2 A simple RC circuit for the frequency response weighting network.

The requirement for a peak-to-peak rectifier is easily achieved by using the doubler circuit shown in Fig. 3. (Note that the draft standard calls for a peak-to-peak rectifier, but a calibration in terms of one-half this value, that is a *peak--not peak-to-peak--calibration*.)

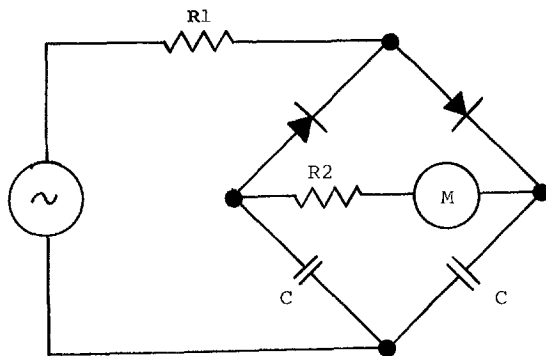

Fig. 3 A simple circuit for the peak-to-peak rectifier, including the necessary time constants $\tau_{\text{chg}} = R1 \cdot C$, and $\tau_{\text{dischg}} = R2 \cdot C$.

The time response is influenced by three things: the integrating and differentiating action of the frequency response weighting network shown above; the charge and discharge time constants of the rectifying network; and the speed of the meter movement (easily specified in terms of its mechanical resonant frequency and the overshoot). The usual design procedure is to design the weighting network, choose the meter movement, and then adjust the rectifying network time constants to obtain the desired time response. A somewhat overdamped meter with a resonant frequency of about 2 Hz is appropriate; a meter with *vu* dynamics (resonant frequency, 2.2 Hz; overshoot, 1 to 1.5%) also could be used. With such a meter and the standard weighting network response, the charging time constant of the network in Fig. 3, $R1 \cdot C$, will be about 30 ms to give the required 62% response for a 30 ms pulse. The discharge time constant $R2 \cdot C$ will be about 1 s, to give the required fall to 40% in 0.9 s. (Note that for the particular test waveform used, the discharge is one capacitor in a series with the meter, rectifier, and source resistances--it is not the two capacitors in a series with the meter.)

3.2 Commercially Available Flutter Meters Meeting The Requirements Of The New Draft Standard.

Since the technical requirements of the new draft standard are identical to those long established by the German Standard DIN 45 507 (1962 and 1966), existing meters to the DIN may be used for the measurement under the new draft IEEE Standard "Method of measurement for subjective flutter of sound recording equipment". Some presently manufactured meters are as follows: (Note that all of these meters have push-buttons or switches which allow them to be used for flutter measurements which are *not* according to the standards.)

Instruments manufactured by DMC (formerly Micom, formerly Bahrs Industries), Palo Alto, Calif.

Model 8100/8100-W, in the "DIN WDT" position *only*.
Model 8155, Option -01 (DIN) only, in the "WTD" position *only*.

Instruments distributed by Gotham Audio, New York, New York.

Models ME-102b and ME-104, in the "fast" ("slow" button out) and "weighted" ("unweighted" button out) positions *only*.

REFERENCES

- [1] F.A. Comerci, "Flutter Index Concept", *J.SMPTE* 71, 1-8 (1962).
- [2] "Methods For Determining Flutter Content In Sound Recorders", IEEE Standard Nr. 193 (also ANSI Z57.1-1954).
- [3] "Messgeräte für Frequenzschwankungen bei Schallspeidgeraten (Measuring Equipment For Frequency Variations In Sound Recording Equipment)", German Standard DIN 45 507-1966.
- [4] "Magnetic Tape Recording and Reproducing (Reel-to-Reel)", Engineering Department, National Association of Broadcasters (USA). See Sections 2.13.01 and 2.13.02.
- [5] "Method of Measurement of Speed Fluctuations in Sound Recording and Reproducing Equipment", IEC draft recommendation, document number 60A(CO)12 (Jan. 1971).
- [6] "Measurement of Wow and Flutter in Recording Equipment and in Sound Reproduction", CCIR Recommendation 409-1 (1966).

APPENDIX A

ON MEASURING SUBJECTIVE FLUTTER*

Ernst Belger
Institute für Rundfunktechnik
Hamburg, West Germany

The major proposals for the measurement of subjective flutter are discussed. It is shown that the measurement of peak value offers considerable practical advantages over an rms measurement. A curve is shown of the subjective evaluation of flutter as a function of flutter frequency; this curve is a compromise between several proposals. These proposals have been adopted as a German standard (DIN 45 507, 1966) and a CCIR Recommendation (409-1, 1966), and are under consideration in the USA by IEEE, and internationally by IEC.

There is an increasing need for a subjective (in addition to objective) measurement of the unavoidable frequency variations ("flutter") created when moving the medium in a sound recorder; in other words, we need measured values which correlate with the audible quality.

The CCIR Recommendation 210 of 1956 specified the test frequency to be used, and the variation-frequency range; but various models of measuring equipment differed from each other in two important points: the kind of rectification, and the weighting curve. {Similarly, the existing ANSI and IEEE standard [1] does not specify the meter dynamics, and does not require a weighting curve.}

1. Rectification

There are a number of studies on the effect of the kind of rectification; these contain some very careful measurements. Most of the tests were done with sine waves, but after many experimental problems were solved, music and speech were also used. The latter deserve special attention, since they correspond to the practical situation. While part of the authors prefer rms measurements, [1,2,4,6] others recommend peak readings [3,5]. We must remember that, in order to obtain the same audible effect, some of these tests were made with frequency-variations (flutter) having a high peak-to-rms ratio.

* Translated from *Rundfunktechnische Mitteilungen* 2, Nr. 4, 168-169 (1958), by Erling Skov, formerly of Ampex Corp.; edited, revised, and updated by John G. McKnight, Ampex Corp.

One would therefore suppose that the correlation between the subjective flutter and the reading on present-day instruments would be very poor. The fact is, however, that the difference between the reading of an rms meter and that of a peak meter is much smaller for the frequency-variations found in practice than for the artificially created frequency-variations mentioned above; therefore the practical importance of the question of peak *vs* rms measurements may be less than these studies would indicate. In other words, one could measure either rms or peak values; in order to obtain comparative readings, however, one must select *one* of the two.

There is a practical reason, however, why the measurement of the peak value seems to be better: When the entire frequency range from 0 to 200 Hz is measured (as specified in the CCIR Rec. 210, 1956) a problem occurs when an rms measurement is attempted at these very low frequencies. While known techniques permit accurate rms readings at mid- and high-frequencies, at low frequencies the pointer moves up and down scale, giving an undefined reading, since the meter does not average over a long enough time to determine the rms value over several periods. When the frequency becomes low enough, the pointer will follow the instantaneous value of the wave, that is, read the peak value at the maxima. Finally, at zero frequency (dc) the rms and peak values are identical.

These difficulties are most easily avoided by reading the rms value at higher frequencies, and the peak value at lower frequencies. Where they overlap two different readings will of course be obtained for the same condition, the ratio of the two depending on the waveshape of the frequency-variations. Although this may be satisfactory for purely comparative measurements, it leads to prohibitive difficulties in a meter where a subjective measurement of audibility is required. This difficulty is avoided if peak readings are used entirely.

Because of this practical advantage, the definitions and measurements of subjective flutter should be in terms of the peak values.

2. Response of the Weighting Network

The necessary frequency weighting has also been determined both for sine-waves and for speech and music programs. As before, the music and speech tests are of the greatest significance.

Even though the results of the different tests differ considerably from each other, there is still a common tendency which cannot be ignored. The various curves from the literature

are shown in Fig. 1; the numbers on the curves correspond to the

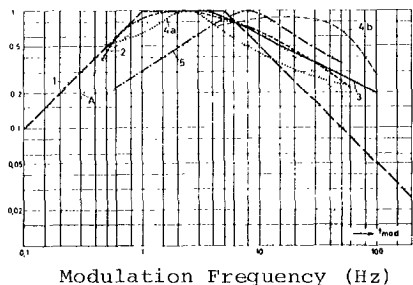

Fig. 1 Weighting factor vs modulation frequency. The numbers on the curves refer to the corresponding works in the References.

reference numbers. Curves 1 to 3 were obtained using sine-waves, and curves 4 and 5 using music and speech. The heavy curves (1 thru 4a) show an interesting coincidence in the range of greatest interest. In curve 5 the maximum is clearly moved toward higher frequencies. Because this data is from very careful and extensive tests using music and speech, it cannot be disregarded, especially since curve 4a (also for music and speech) shows a similar tendency in this direction. The curve 4b (obtained using the same program) is less important here since it is valid only for transmission by lower quality systems. It is nevertheless interesting that even here a greater weighting is used for the higher frequencies. Judging from the existing material, one can conclude that with normal programs (i.e., with sounds of relatively short duration) lower modulation frequencies are less apparent than with continuous tones. The curve shown in Fig. 2 is a compromise between the different data in the literature (it is shown in light weight in Fig. 1 as "A").

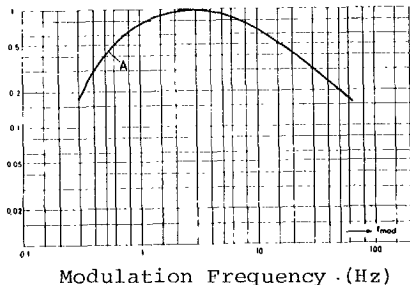

Fig. 2 Compromise proposal for the weighting factor vs modulation frequency, on the basis of the curves specified in Fig. 1.

Since it can hardly be expected that a final solution for the optimum curve shape can be obtained for the average of all of the program material of interest, the recommendation for a single measuring method for the measurement of subjective flutter ans wow uses the curve of Fig. 2 for the frequency weighting. This curve is easy to realize in practice.

3. Standardization

The subjective flutter measurement method described herein has been incorporated in the German Standard DIN 45 507, first published in 1962, with minor revisions in 1966. The method is also incorporated in the CCIR Recommendation 409-1, 1966; minor clarifications have been proposed to that standard. The weighting curve given here is incorporated into the flutter measurement method given by NAB in their 1965 tape recording (open-reel) standard, although the peak-measurement method was not included at that time due to lack of experience at that time with the peak-measuring method.

The IEC is currently (1971) considering adopting this subjective flutter measuring method, as is the IEEE.

References:

- [1] CCIR Doc. 187 (VIIth Plenary Ass'y, London, 1953): submission by USA. (Substantially identical to IEEE No. 193, also ANSI Z57.1-1954, "American Standard Method for Determining Flutter Content of Sound Recorders and Reproducers".)
- [2] CCIR Doc. 364 (VIIIth Plenary Ass'y, Warsaw, 1956): submission by Japan, "Measurement of 'Wow' and 'Flutter'".
- [3] CCIR Doc. 65 (VIIIth Plenary Ass'y, Warsaw, 1956): submission by Federal German Republic, "Investigation of Methods for Measuring 'Wow' and 'Flutter'". (This report is essentially an English-language summary of the following German papers:
- 1) E. Zwicker, "Grenzen der Hörbarkeit der AM und FM eines Tones" ("The Limits of Audibility of AM and FM of a Tone") *Acustica* 2, Beiheft 3, 125-133, AB 125 (1952).
 - 2) E. Zwicker and W. Kaiser, "Der Verlauf der Modulationsschwellen in der Hörfläche" ("The Location of the Modulation Threshold in the Area of Hearing"), *Acustica* 2, Beiheft 4, 239-246, AB 239 (1952).
 - 3) E. Zwicker, "Über die Hörbarkeit nichtsinusförmiger Tonhöhenchwankungen" ("On the Audibility of Non-Sinusoidal Pitch Variations"), *Funk und Ton* 7, 342-346, (1953).
- [4] F. Comerchi and E. Oliveros, "An Audio Flutter Weighting Network", *J. Soc. Mot. Pict. Engrs.* 65, 419-425, (1956).
- [5] A. Stott and P.E. Axon, "The Subjective Discrimination of Pitch and Amplitude Fluctuations in Recording Systems", *Proc. IEE (London)* 102, 643-656 (Sept. 1955).
- [6] CCIR Doc. 192 (VIIth Plenary Ass'y, London, 1953): submission by United Kingdom. (Identical to "Memorandum on the Measurement of Frequency Variation in Sound Recording and Reproducing", British Standards Institution B.S. 1988:1953.)

THIRD DRAFT
19 Oct. 1970
J.G. McK.

APPENDIX B

IEEE

Audio and Electroacoustics Standards Committee

Sound Recording Sub-committee

METHOD OF MEASUREMENT FOR SUBJECTIVE FLUTTER OF SOUND RECORDING EQUIPMENT

1. Scope

This standard specifies a "weighted quasi-peak" method of measurement for subjective flutter of sound recorders and reproducers for normal audio usage. For special purposes--high speed duplicators, different speeds in recording and reproducing, etc.--special procedures not described here must be used.

An Appendix gives explanatory notes concerning subjective flutter measurements.

2. Definitions

Flutter, wow, drift, and frequency-modulation noise are all forms of distortion caused by undesired frequency modulation introduced into the signal by an irregular motion of the recording medium during the recording, duplicating, and/or reproducing processes. For the purposes of this Standard, the following definitions shall apply:

Subjective flutter: Flutter and wow measured with a weighted quasi-peak equipment according to this Standard.

Flutter: The distortion perceived as a roughening of the sound quality, and caused by modulating frequencies in the range of approximately 6 Hz to 100 Hz.

Wow: The distortion perceived as a fluctuation of the pitch, and caused by modulating frequencies in the range of approximately 0.5 Hz to 6 Hz.

Drift: The distortion perceived as a slow drifting of the average pitch, and caused by modulating frequencies below approximately 0.5 Hz. Measurement of drift is not covered by this standard.

Frequency-modulation (friction) noise ("scrape flutter"): A distortion perceived as a noise added to the signal (not present in the absence of a signal), and caused by modulating frequencies above approximately 100 Hz. Measurement of frequency-modulation noise is not covered by this standard.

Measurement of subjective flutter

- 3.1 A method giving the weighted peak value shall be used for the measurement of subjective flutter for sound recording equipment.
- 3.2 The measurements shall be made at a frequency of 3150 Hz in accordance with ANSI S1.6-1967, "Preferred frequencies for acoustical measurements".

Note: The frequency of 3000 Hz has also been used commonly in the past.

- 3.3 The measurements of normal recording and reproducing systems shall be made on one element only of the system (either the recorder or the reproducer, but not on both) under such conditions that the subjective flutter in the remaining parts of the measuring system is negligible.

Note: When this condition cannot be fulfilled, a recorder/reproducer may be measured by recording a 3150 Hz test frequency and subsequently reproducing this record and measuring the total subjective flutter. Subjective flutter shall not be measured while simultaneously recording and reproducing.

- 3.4 The subjective flutter of delay devices (whose normal mode of operation employs simultaneous recording and reproducing) shall be measured while simultaneously recording and reproducing.
- 3.5 Because of the finite decay time of the measuring equipment it is impossible to avoid variations in the reading with frequency variations of very low frequency, or of a random nature. In this case, the maximum value should be read.

3.6 In most sound recording equipment the subjective flutter will vary with system conditions such as the speed of the medium in a multi-speed system, the tape-pack diameter in a tape recorder (e.g., from beginning to end of a reel), the number of discs on a phonograph record changer, etc. The subjective flutter should therefore be measured and reported for each of the various pertinent conditions. A single value of subjective flutter reported for a system whose subjective flutter varies with system conditions shall be for the worst combination of factors.

4. Reporting results

Subjective flutter measured in accordance with this standard shall be reported in the following manner:

"Subjective flutter of the recorder: + ___%", or
 "Subjective flutter of the reproducer: + ___%", or
 "Subjective flutter of the recording/reproducing system: + ___%."

A statement of conditions may also be necessary (see Sec. 3.6).

5. Measuring equipment

The measuring equipment shall have the following characteristics.

5.1 Response curve

As specified in Table I and Figure 1.

Note: An unweighted response flat at least between 0.2 and 200 Hz would provide useful additional information about the source of flutter and wow. Tolerances and dynamic characteristics are not specified for the unweighted response.

5.2 Rectifier law

The rectifier shall measure the peak-to-peak value of the wave (see also Sec. 5.3).

5.3 Calibration

The instrument shall be calibrated in terms of a sinusoidal frequency modulation. The scale shall indicate the peak value (one-half of the peak-to-peak value) of the subjective flutter, as "+ ___%".

TABLE I
WEIGHTING FACTORS.

Frequency Hz	Weighting Factor e_f	Weighting Level $20 \lg \frac{e_f}{e_{f_0}}$ [dB]	Tolerances
0.2	0.0296	-30.6	at 0.2 Hz +10 dB - 4 dB
0.315 0.4	0.103 0.173	-19.7 -15.0	from 0.315 Hz to 0.5 Hz ± 4 dB
0.63 0.8 1 1.6 2	0.380 0.500 0.617 0.812 0.900	- 8.4 - 6.0 - 4.2 - 1.8 - 0.9	from 0.5 Hz to <4 Hz ± 2 dB
4	1.000	0	at 4 Hz ± 0 dB
6.3 10 20 40	0.900 0.788 0.508 0.301	- 0.9 - 2.1 - 5.9 -10.4	from >4 Hz to 50 Hz ± 2 dB
63 100 200	0.195 0.157 0.0705	-14.2 -17.3 -23.0	from 50 Hz to 200 Hz ± 4 dB

B4

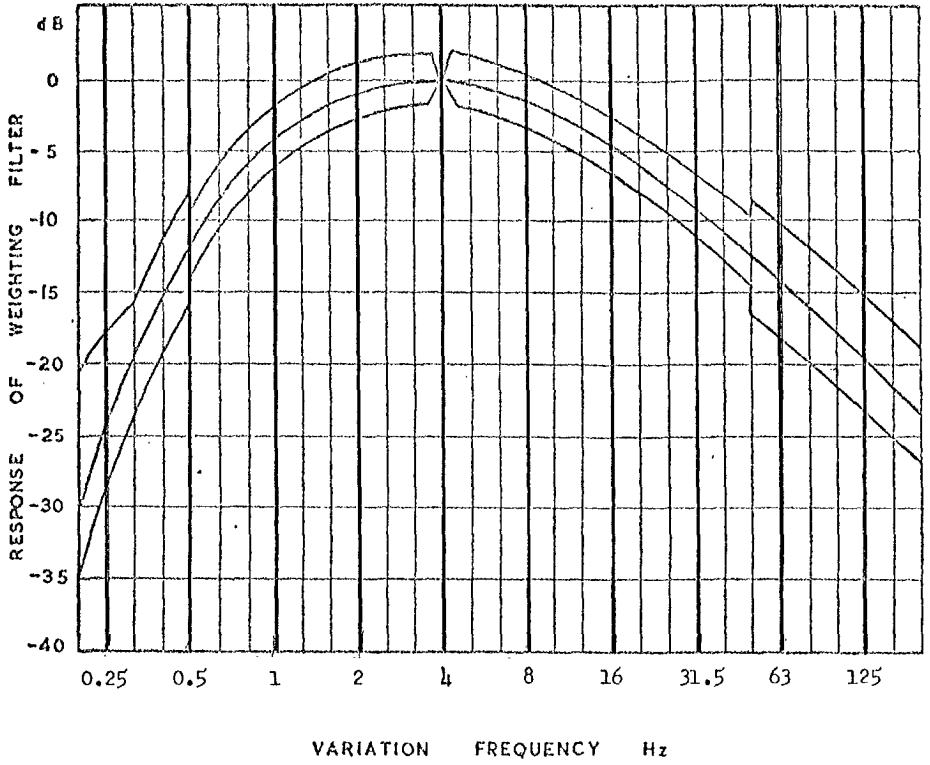

FIG.1 WEIGHTING CURVE

5.4 Dynamic characteristics

The dynamic characteristics of the complete measuring equipment including the weighting network shall be such as to give the meter indications as tabulated below, when measured by the following procedure:

- a. Apply to the equipment a 3150 Hz signal which is frequency-modulated with a 4 Hz sinusoid. Adjust the deviation so as to give a convenient reading on the flutter meter; this reading will be taken as the reference reading.
- b. Replace the sinusoidal modulation in *a* with a short unidirectional impulse modulation as shown in Fig. 2, having a repetition rate of one pulse per second, a pulse length *A*, and a peak-to-peak deviation equal to the peak-to-peak deviation used for the reference sinusoid in *a*; that is, $\Delta f_{\text{pulse}} = 2\Delta f_{\text{sin max}}$.

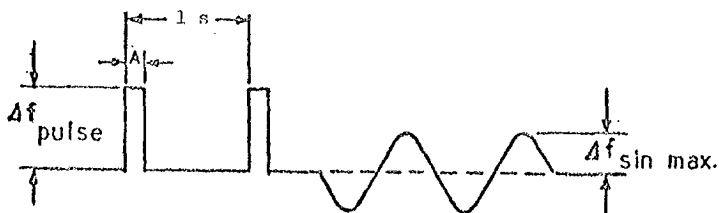

FIG. 2

- c. The meter shall indicate the fractions *B* of the indication with the reference sinusoid, when the pulse length has the values *A*:

Pulse length, <i>A</i>	ms	10	30	60	100
Relative indication, <i>B</i>	%	21±3	62±6	90±6	100±4

- d. When pulses of 100 ms duration and a repetition rate of one pulse per second are applied, the decay time of the equipment shall be such that between the pulses the indicator shall fall to a reading in the range of from 36% to 44% of the maximum reading created by the pulse.

6. Good engineering practice

The following items are not fundamental to this standard, but are matters of good engineering practice.

- 6.1 The measuring equipment should operate within the limits stated below for a test frequency between at least 3050 Hz and 3250 Hz.

- 6.1.1 Using the least sensitive range, the indication for frequencies of 0.8 Hz and 20 Hz should be linear up to full scale.

Note: Because of the weighting network, amplifier overload may occur although the meter indications be less than fullscale. Therefore it may be desirable to have provision for overload conditions which are greater than the normal full-scale value.

- 6.1.2 When measuring a 4 Hz sinusoidal frequency modulation under steady-state conditions, the error of indication should not exceed +10% of the normal full-scale value. This error should not exceed +15% for any of the conditions shown below.

- 6.1.2.1 Input voltage deviation of +6 dB during the measurement.

- 6.1.2.2 Thirty per cent rectangular amplitude modulation of the input voltage at a frequency of 4 Hz at a reading of +0.15% subjective flutter.

- 6.1.2.3 Frequencies up to 180 Hz (for example, hum) contributing up to 20% rms in the input voltage.

- 6.1.2.4 Line voltage deviations of +10%.

- 6.1.2.5 Room temperatures between 15 and 35°C (measured after a warming-up period of 15 minutes).

- 6.1.2.6 External 50 or 60 Hz field of 4 amperes/metre (approximately 50 mOe).

- 6.2 The required input voltage should not exceed 100 mV. An indication of the correct input voltage is desirable.
- 6.3 The input impedance should not be less than 300 kilohms at 3150 Hz.
- 6.4 Provisions for connecting external filters or other analyzing equipment, for example an oscillograph, are desirable. Approximately 0.1 V to 1 V output should be provided for all full-scale readings.

Appendix

Explanatory Notes

In sound recording, it is impossible to obtain absolutely constant speed of the recording medium because of the limited precision of the mechanical drive (disc turntable, or tape or film transport). This standard is concerned with the relative audible effect of the short-time variations--subjective flutter. In addition, there is also often a difference between the average speed at the beginning and at the end of the recording, and an error of the average speed itself. These latter two effects are not considered in this standard.

Definitions

The name of the quantity measured here--which could be called "subjective flutter and wow"--has been shortened to "subjective flutter", for brevity. This is also in accordance with the common usage of the term *flutter* to include all modulating frequencies from 0.5 Hz to 200 Hz.

Method

For a constant frequency, f , the wavelength λ varies in recording proportionately to the transport speed according to the equation $\lambda = v/f$. When reproduced with a perfect drive ($v = \text{constant}$), the frequency which was so recorded will show a corresponding frequency modulation. In practice, however, the reproducing system adds its own speed variations, and the consequent frequency modulation adds vectorially to that from the recording.

The subjective flutter of a recorder is best measured by reproducing its recording on a transport having speed variations much smaller than those of the transport under test. Similarly, for a reproducer, the subjective flutter

is best measured by reproducing a test record made with a transport having speed variations much smaller than those of the transport under test. For a recorder/reproducer, a specification of the subjective flutter of the equipment as a reproducer alone is usually completely satisfactory, and is usually less subject to measuring error than the combined measurement of the recorder/reproducer.

When no such test record or recording or reproducing transport is available, recording and reproducing is usually done on the transport under test. Therefore vectorial addition of the two identical variations occurs, and the resulting variations depend upon the phase relation between the two components. In extreme cases, the result is very nearly arithmetic addition.

Subjective measurement

Because the perceptibility of frequency variations depends on the variation frequency, the measurements are performed with a weighting filter which approximates these characteristics of the ear-brain mechanism.

The fact that the frequency variations are normally non-sinusoidal makes it necessary also to specify the characteristics of the rectifier circuit and the indicating instrument. A quasi-peak rectifier has been found to be most suitable. The peak-to-peak rectification required may be obtained, for instance by the use of a voltage doubler circuit.

This combination of weighting and quasi-peak rectifier has been found to give measured values of subjective flutter which correlate well with subjective evaluations made by listening panels.

Frequency modulation (friction) noise ("scrape flutter")

For modulation frequencies above approximately 100 Hz the disturbing effect is called "frequency modulation noise", "friction noise", or "scrape flutter". The audibility depends mostly on the frequency and the sound pressure level of the *transmitted* tones. Under certain conditions (mainly the use of sinusoidal tones) this effect may be quite audible. In order to obtain consistent flutter readings, the weighting curve of the present standard is defined up to 200 Hz. The measurement of frequency modulation noise, however, requires special measuring procedures not given in this standard. (Since the ear is unable to distinguish amplitude modulation noise from frequency modulation noise for modulating frequencies above approximately 100 Hz, the two measurements might better be combined into a single "high-frequency modulation noise" measurement.)

Comparison with other measurements

Unweighted rms flutter and wow measurements have commonly been used in the past. In general, the results are in no way related to the subjective evaluation of the flutter and wow, and the measurements cannot be compared directly with the measurement of subjective flutter.

System Conditions

Many recording systems operate at several speeds, and the subjective flutter is usually different at the different speeds. It is therefore usual to give a separate subjective flutter measurement for each speed. A much more difficult problem is the variation of subjective flutter with other variables which depend on the design of each particular recording system. Examples would be the number of discs on a record changer, the tape-pack diameter on a tape recorder (worst subjective flutter usually occurs at the end of a small hub supply reel), the thickness and surface finishes of tape on a tape recorder and the temperature of the system. It is the intention of this standard that the reported subjective flutter represent the worst value that will occur with the equipment when operated under normal conditions as defined in the system's specifications.

Reference

E. Belger, "Zur messung von Tonhöenschwankungen (On measuring subjective flutter)", *Rundfunktechnische Mitteilungen* 2, 168-169 (1958). English translation to be published.

ADDITION TO AES PREPRINT 790:
DEVELOPMENT OF A SUBJECTIVE FLUTTER MEASUREMENT STANDARD

A fourth draft of the proposed flutter measurement method has been prepared, to incorporate comments received in balloting the proposal, and also to incorporate changes made in the corresponding IEC draft recommendation. The following describe the essential changes.

TITLE: METHOD OF MEASUREMENT FOR WEIGHTED PEAK FLUTTER OF SOUND RECORDING AND REPRODUCING EQUIPMENT.

Throughout the draft, "subjective" is replaced by "weighted peak", since this measurement is an objective measurement to *predict* subjective flutter. (A subjective measurement must be made by an actual person listening, according to accepted acoustical usage.)

Add Definition: Weighting: The use of a psychoacoustically determined time-response and frequency-response in an objective measuring equipment. This is done in order to obtain indications which better predict the subjective values than would wideband measurement with a meter having either an instantaneous time response, or a long-time average or rms response.

Sec. 3.3, Note: Add for this method that the weighted peak flutter is measured several times, and the arithmetic average value calculated and reported.

Table and Fig. 1: Weighting factor extended to -48 dB at 0.1 Hz.

Sec. 6.1: Minimum frequency range over which the measuring equipment must operate within specified limits changed to 3000 Hz to 3300 Hz. Thus old test records at 3000 Hz would be usable on new measuring equipment.

Sec. 6.4: Add to read "Provisions for connecting external ... equipment ... to the demodulator output, both with and without the frequency-response weighting, are desirable."

Appendix, Comparison with other measurements: Add information that this standard is based on the IEC draft recommendation, is consistent with present weighted peak measurements given by CCIR and DIN Standards, and gives readings approximately proportional to the "NAB weighted" readings.

22 April 1971
J.G. McKnight